

MAGNETIC FORK TIP PROTECTOR - FPU-TN-45-M-OR

APPROX WEIGHT: 0.1503 lbs.
DOES NOT INCLUDE WEIGHT OF POWER OR PACKAGING!!!

*** ANY ADDITIONS, DELETIONS, OR OMISSIONS MUST BE CORRECTED ON THIS DRAWING AS THIS DRAWING WILL BE CONSIDERED ALL INCLUSIVE ***

ALL GRAPHICS PROVIDED ARE FOR REFERENCE ONLY. IF CERTAIN DIMENSIONS ARE CRITICAL PLEASE VERIFY THOSE DIMENSIONS WITH YOUR SALESPERSON

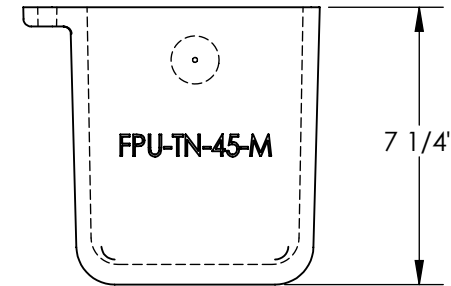
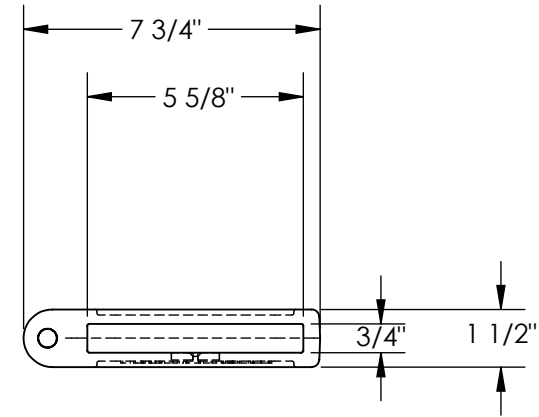
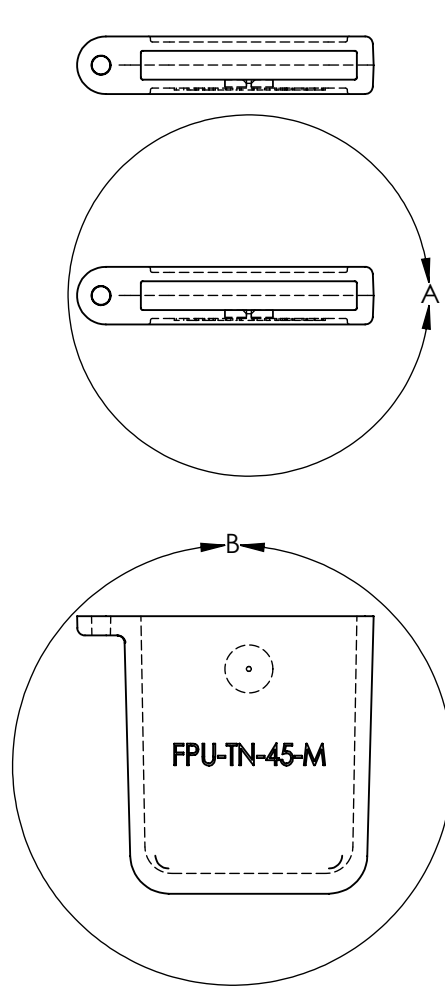

DIMENSION TOLERANCE $\pm 1/4$ "

STANDARD FEATURES

MODEL NUMBER IS: FPU-TN-45-M-OR
COMES WITH TWO FORK TIP PROTECTORS
w/ EMBEDDED MAGNET
OVERALL LENGTH IS: 7 1/4"
OVERALL WIDTH IS: 7 3/4"
OVERALL HEIGHT IS: 1 1/2"
FORK POCKET IS: 5 5/8" X 3/4"
FOR USE WITH 4" AND 5" WIDE FORKS
COLOR IS ORANGE FOR USER SAFETY
MADE FROM POLYURETHANE

SPECIAL FEATURES

NONE

APPROVAL

I, THE UNDERSIGNED, AGREE THAT THE PRODUCT AS REPRESENTED SATISFIES DESIGN AND DIMENSION REQUIREMENTS. I ALSO ACKNOWLEDGE MY DUTY TO CONFIRM PRODUCT AND INSTALLATION COMPLIANCE WITH ALL APPLICABLE FEDERAL, STATE AND LOCAL REGULATIONS AND STANDARDS.
UNITS REQUIRING APPROVAL DRAWINGS OR MODIFIED ARE NON-RETURNABLE

As drawn As marked

Signed: _____ Date: _____

Printed Name: _____

LEAD TIME WILL START UPON RECEIPT OF SIGNED APPROVAL DRAWING

DISTRIBUTOR'S NAME:		P.O.#
VESTIL MANUFACTURING		X
DRAWN BY: JGP		W.O.#
DATE: 10/22/2021		X
REFERENCE: X	SCALE: 1:5	SALES: X
QUOTED LEAD TIME: X	QUOTE #	FILE NAME:
	X	29-007-344